

City Leadership Voting Results

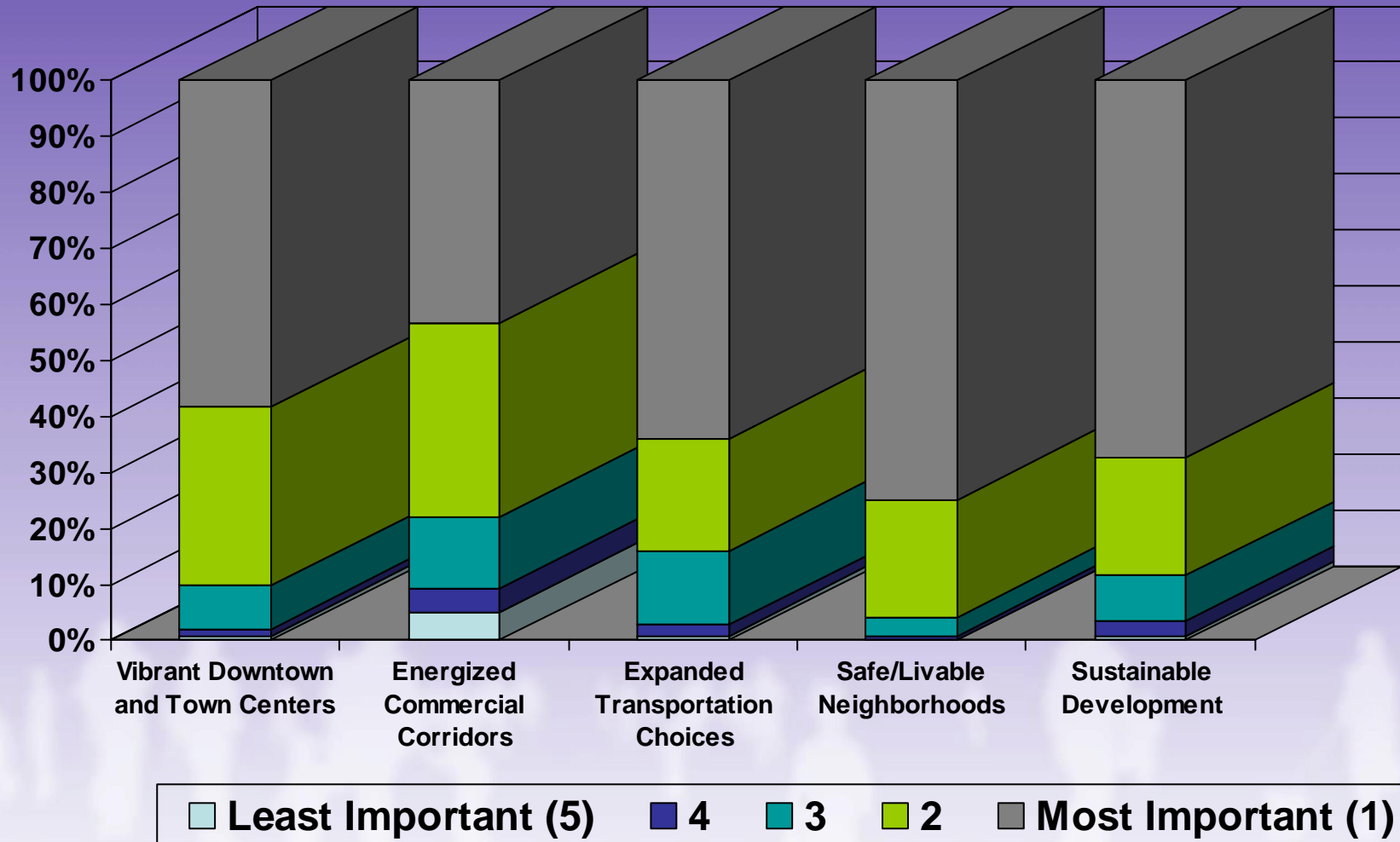

Vision and Guiding Principles



Vision and Guiding Principles

Comments:

- Spread vibrancy everywhere
- Housing choices
- Balance skyline with livability
- Arts & culture emphasis
- Maximize mixed use
- Jobs/housing balance
- Make unique places
- Mobility choices
- Flood protection #1
- River access very important
- Focus on growing tree canopy
- Be “green” in all things

Richards Boulevard Land Use – Preliminary Conclusion

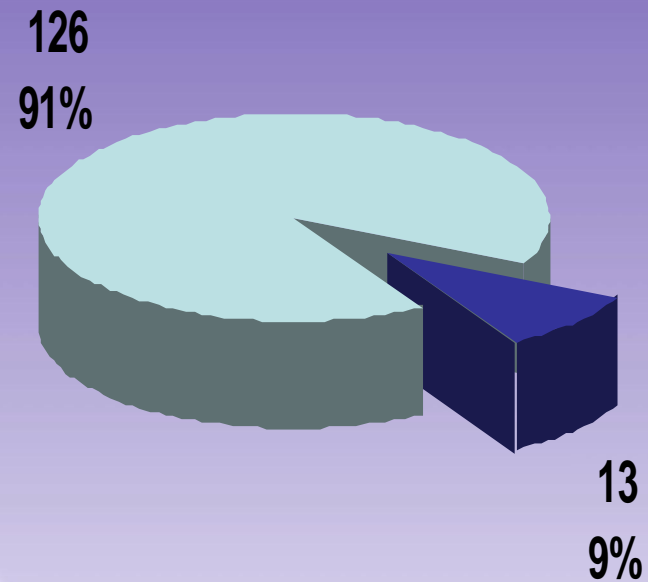

■ Generally Support

■ Do Not Support

Railyards

Land Use – Preliminary Conclusion

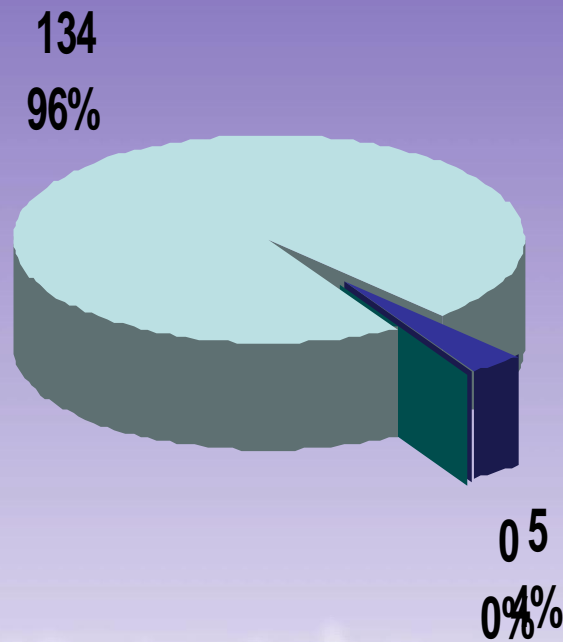

■ Generally Support ■ Do Not Support ■ No Answer

Executive Airport Land Use – Preliminary Conclusion

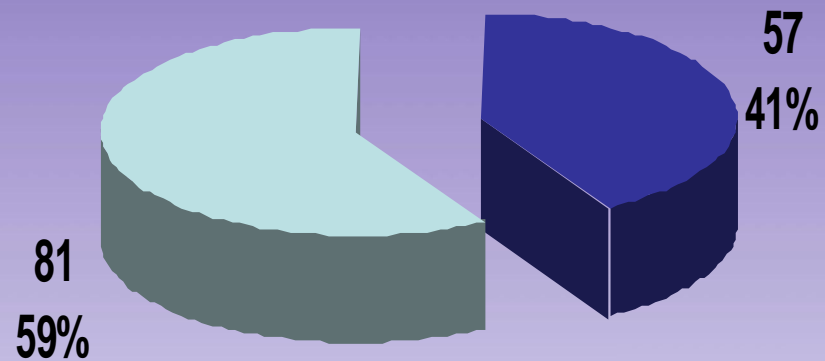

■ Generally Support

■ Do Not Support

Comments

- Leverage River Access
- Focus on Connectivity to Rest of City
- Maximize Housing Opportunities
- Openness to Wide Array of Funding Options



Key Challenges

Infrastructure Financing

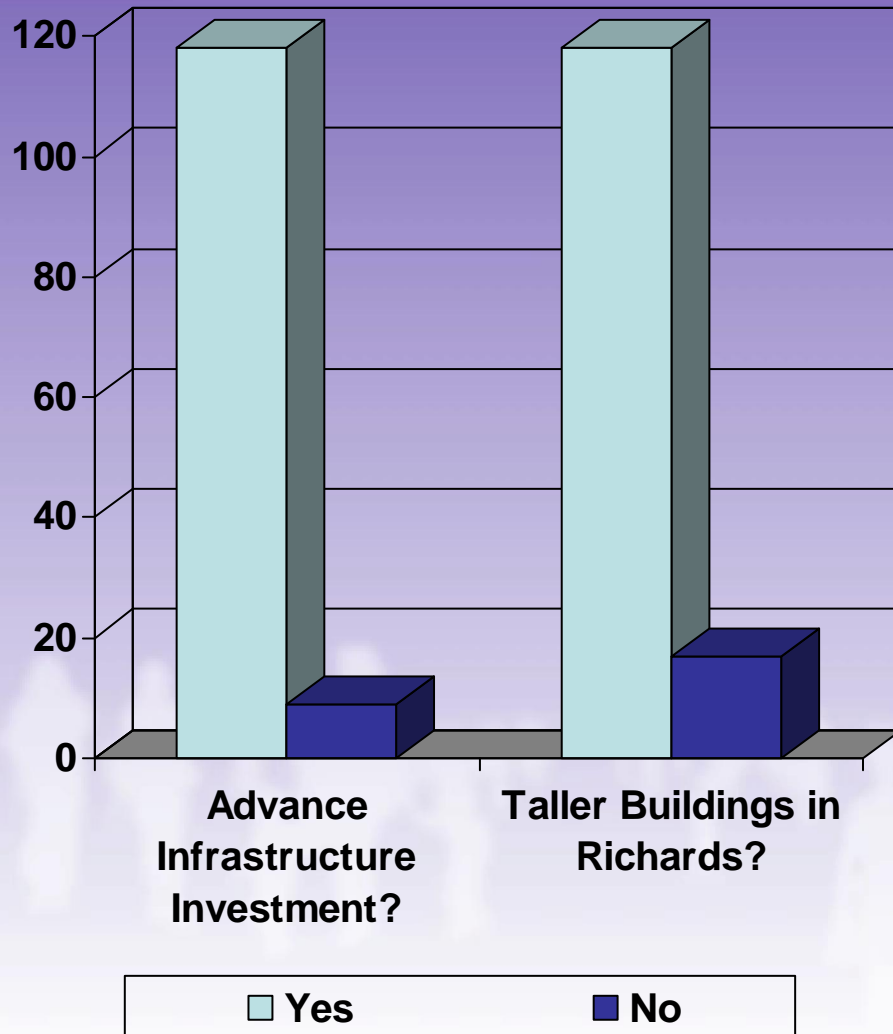

How do we fund public transportation improvements?

- xxx
- Xxx
- Xxx
- Xxx
- xxx

Natomas Joint Vision Area Land Use – Preliminary Conclusion

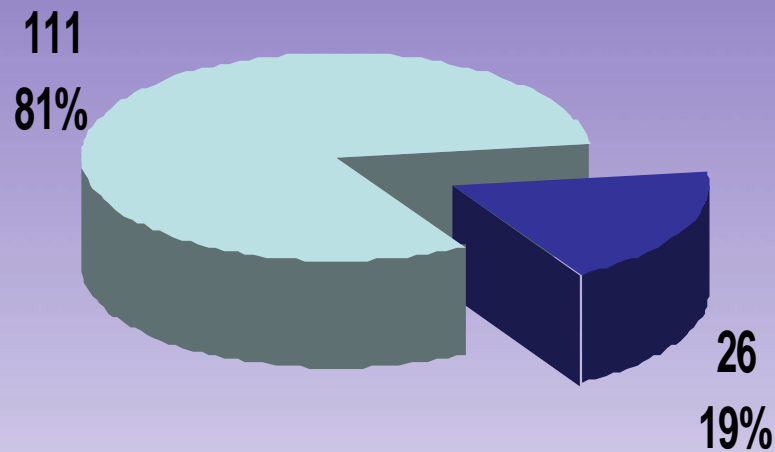

■ Generally Support

■ Do Not Support

East Area New Growth Land Use – Preliminary Conclusion

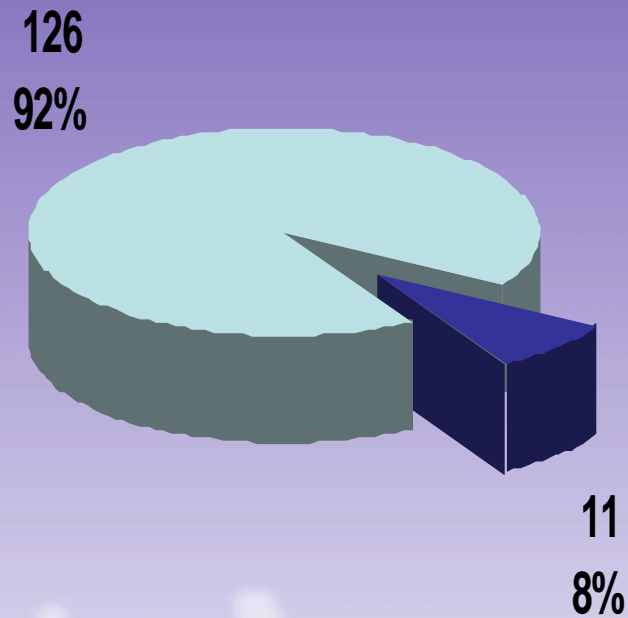

■ Generally Support

■ Do Not Support

Delta Shores Land Use – Preliminary Conclusion

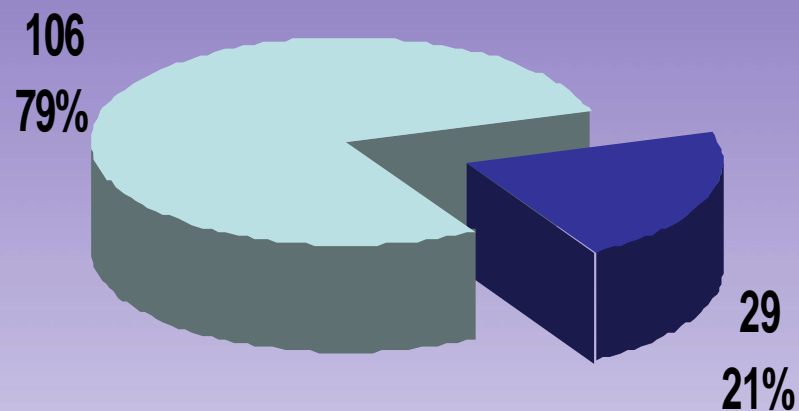

■ Generally Support

■ Do Not Support

Key Challenges

Regional Consensus on Smart Growth

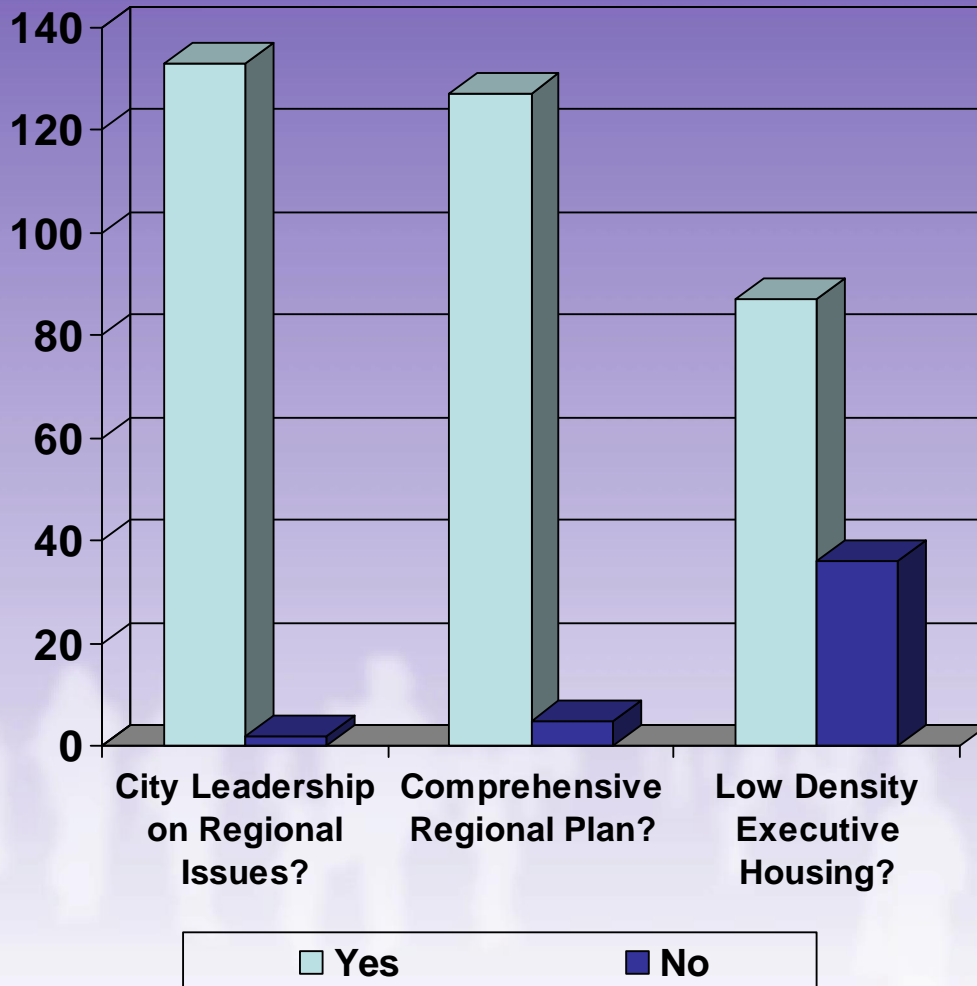

Delta Shores

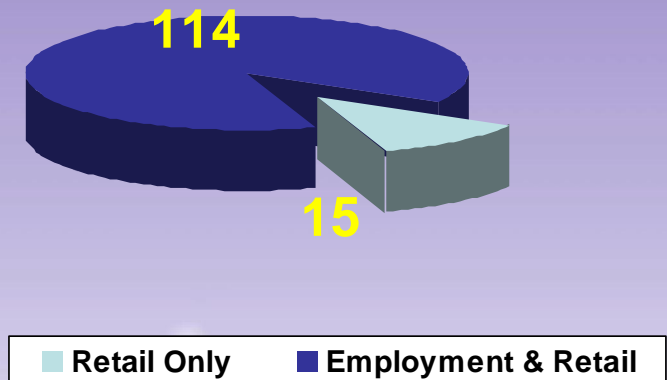

Comments

- East Area Growth Fewest Concerns
- Natomas Growth Contingent Upon Adequate Flood Control & Open Space
- Desire for Annexation Boosts Control
- Mixed Vision for What Delta Shores Could Be

Central Business District Land Use – Preliminary Conclusion

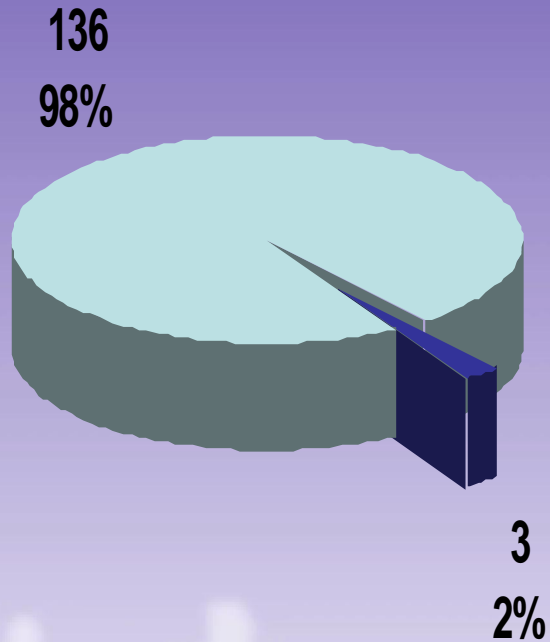

■ Generally Support

■ Do Not Support

Sub-Regional Centers Land Use – Preliminary Conclusion

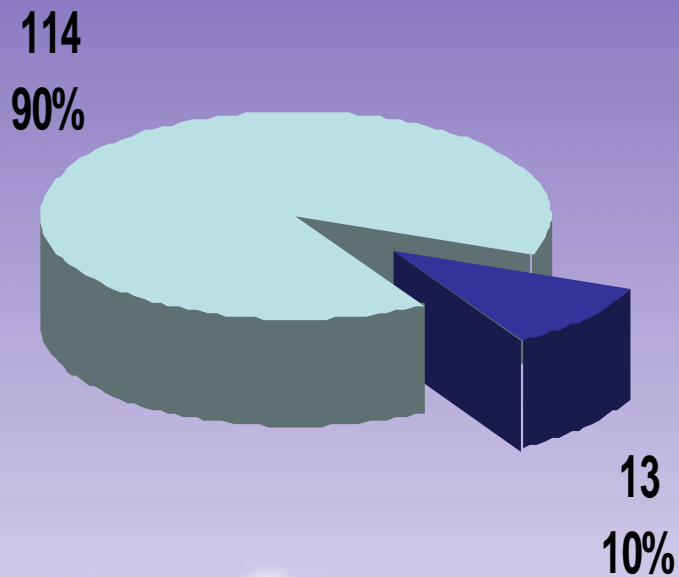

■ Generally Support

■ Do Not Support

Employment Centers Land Use – Preliminary Conclusion

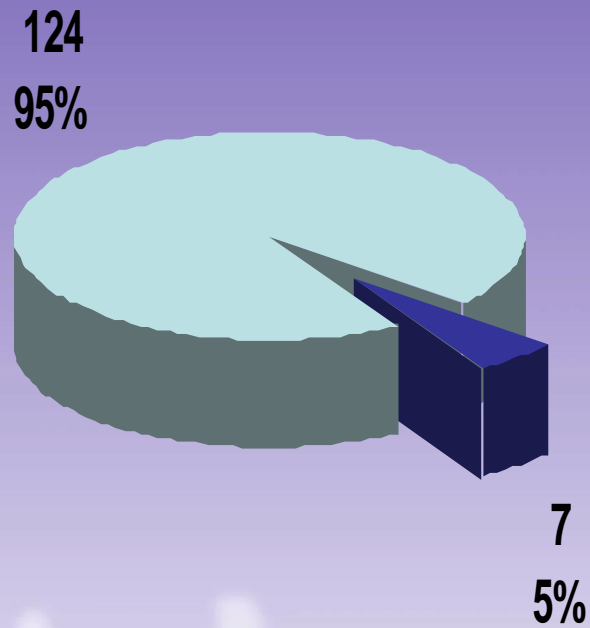

■ Generally Support

■ Do Not Support

Key Challenges

Traffic and Congestion

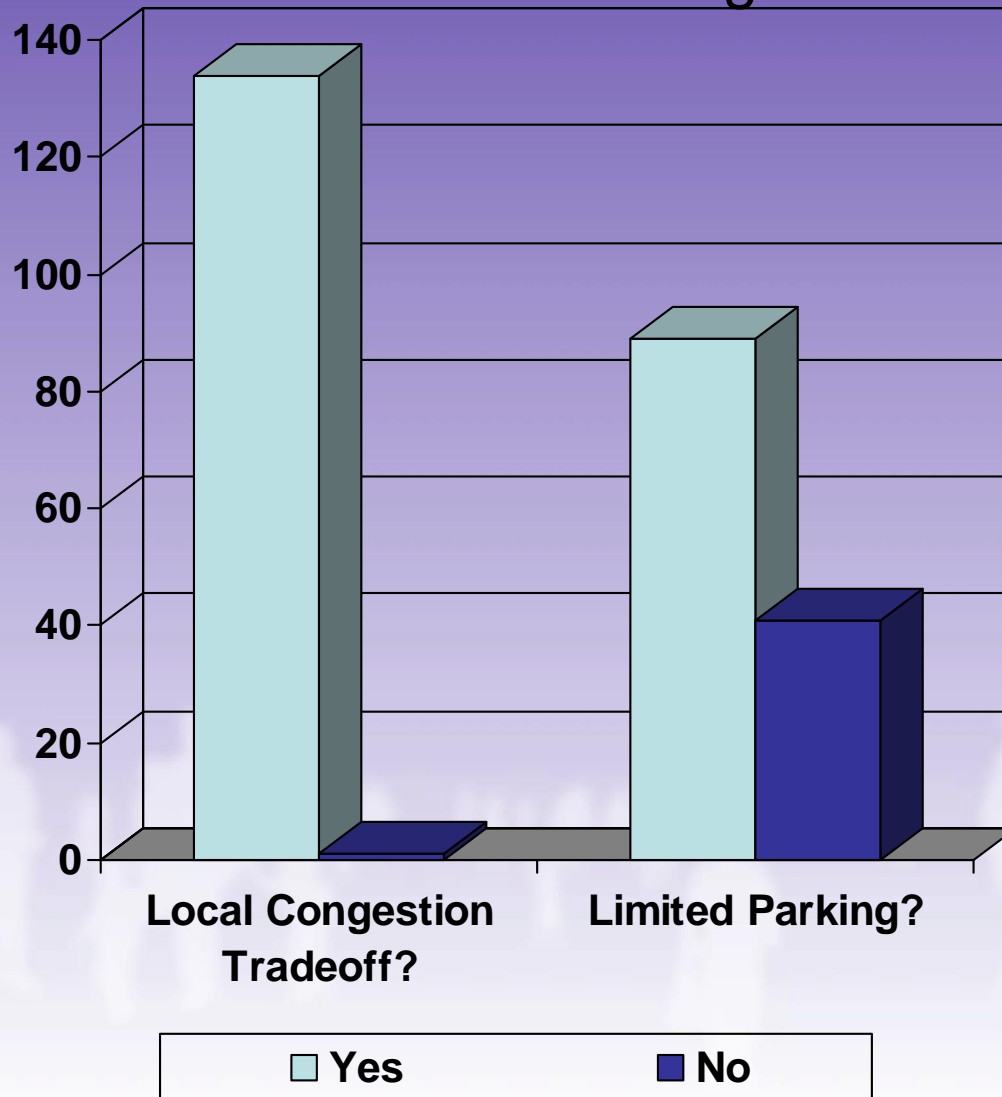

Comments

- Overwhelming support for districts and centers
- Employment and subregional centers must be linked to transit
- Must be compatible with city fabric
- Housing critical for 24/7 living

Mixed Use Corridors Land Use – Preliminary Conclusion

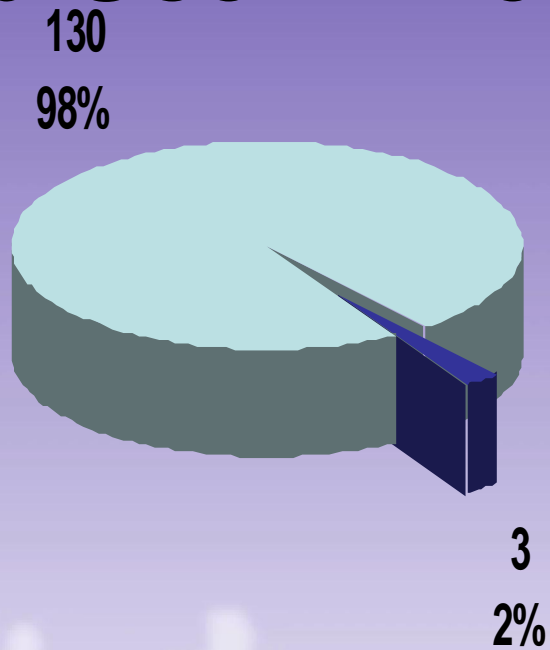

■ Generally Support

■ Do Not Support

Transit Centers Land Use – Preliminary Conclusion

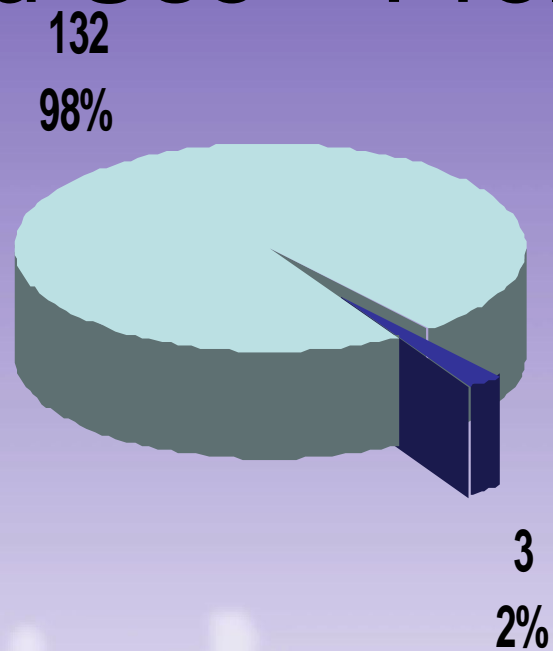

■ Generally Support

■ Do Not Support

Commercial Centers Land Use – Preliminary Conclusion

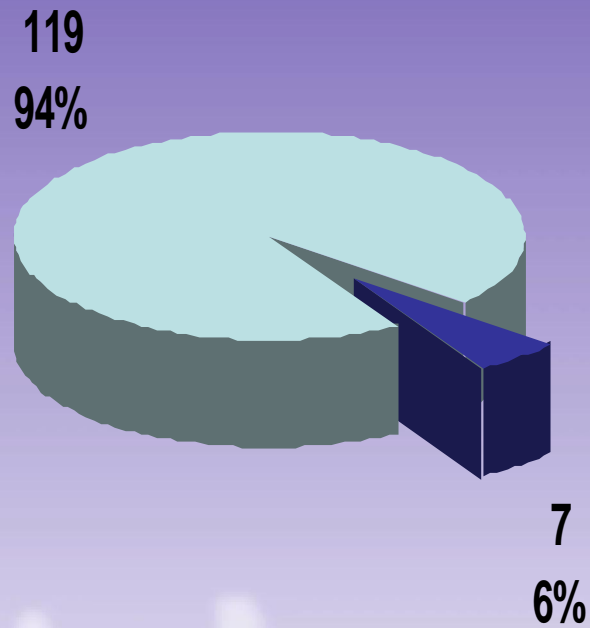

■ Generally Support

■ Do Not Support

Key Challenges

Protection and Enhancement of Neighborhood Character

